

FLOTAC: new multivalent techniques for qualitative and quantitative copromicroscopic diagnosis of parasites in animals and humans

Giuseppe Cringoli¹, Laura Rinaldi¹, Maria Paola Maurelli¹ & Jürg Utzinger²

¹Department of Pathology and Animal Health, Faculty of Veterinary Medicine, University of Naples Federico II, CREMOPAR Regione Campania, Naples, Italy.

²Department of Public Health and Epidemiology, Swiss Tropical Institute, Basel, Switzerland. Correspondence should be addressed to G.C. (cringoli@unina.it).

Published online 25 February 2010; doi:10.1038/nprot.2009.235

Accurate diagnosis of parasitic infections is of pivotal importance for both individual patient management and population-based studies, such as drug efficacy trials and surveillance of parasitic disease control and elimination programs, in both human and veterinary public health. In this study, we present protocols for the FLOTAC basic, dual and double techniques, which are promising new multivalent, sensitive, accurate and precise methods for qualitative and quantitative copromicroscopic analysis. These various methods make use of the FLOTAC apparatus, a cylindrical device with two 5-ml flotation chambers, which allows up to 1 g of stool to be prepared for microscopic analysis. Compared with currently more widely used diagnostic methods for parasite detection in animals (e.g., McMaster and Wisconsin techniques) and humans (e.g., Kato-Katz and ether-based concentration techniques), the FLOTAC techniques show higher sensitivity and accuracy. All FLOTAC techniques can be performed on fresh fecal material as well as preserved stool samples, and require approximately 12–15 min of preparation time before microscopic analysis.

INTRODUCTION

The critical need for effective diagnostics

The achievement of high quality with regard to diagnosis of infectious and parasitic diseases requires development of multivalent techniques that are characterized by high sensitivity, specificity, accuracy, precision, reproducibility and the capacity to rapidly detect and monitor infections that pose human and veterinary public health problems¹. This is important not only for individual diagnosis to improve patient management but also for population-based epidemiological investigations, such as anthelmintic drug efficacy trials, monitoring drug resistance, and surveillance of parasitic disease control and elimination programs. Anthelmintic drug resistance has been widely assessed in livestock worldwide, using diagnostic approaches with different levels of sensitivity². The issue of drug resistance for human helminthiasis is also of considerable public health concern³, particularly in view of growing drug pressure in the era of 'preventive chemotherapy,' which is the large-scale application of anthelmintic drugs to at-risk populations (e.g., school-aged children) without prior diagnosis^{4,5}. Moreover, for the so-called neglected tropical diseases, there is a tendency to focus research on drug and vaccine development rather than diagnostics^{6,7}.

Diagnostic approaches based on fecal egg count (FEC) enable detection of parasitic elements (PEs) in animals and humans. Although these techniques are quantitative, and hence allow infection intensities to be determined, diagnosis is often only made qualitatively (presence or absence of an infection). For herbivores, although, quantification is the norm rather than the exception. When quantification is pursued, PEs (e.g., eggs, larvae, oocysts and cysts) are counted and usually expressed as the number of PEs per gram of feces (i.e., EPG, LPG, OPG and CPG, respectively). FEC techniques are considered relatively straightforward and protocols such as the McMaster technique^{8,9} and the Wisconsin flotation technique¹⁰ in the veterinary field¹¹, and the Kato-Katz technique^{12,13} and the ether-based concentration method^{14,15} in the human field have been available for many years.

Strengths and limitations of current diagnostic techniques

The McMaster technique is the most widely used FEC technique in veterinary parasitology and is advocated by the World Association for the Advancement of Veterinary Parasitology (WAAVP) in its guidelines for evaluating the efficacy of anthelmintic drugs in ruminants¹⁶ and for detection of anthelmintic resistance¹⁷. A host of modifications of the basic McMaster technique have been described^{18–21}, pertaining to variation in the weight of feces examined, volume of water and/or flotation solution (FS) employed, application of additional centrifugation, duration and speed of centrifugation, selection of FS, time the sample remains in flotation and the number of sections of the McMaster slide counted under a microscope²⁰. The Wisconsin technique consists of a flotation of tubes in centrifuge, and this method has been advocated for recovering nematode eggs in cattle, particularly for the discovery of low egg counts²².

Owing to its simplicity and relatively low cost, the Kato-Katz technique is recommended by the World Health Organization (WHO) for epidemiological surveys and surveillance pertaining to intestinal schistosomiasis and soil-transmitted helminthiasis control programs⁴. The ether-based concentration method¹⁵ is also widely used, particularly in reference laboratories²³. Two important features of the ether-based concentration method are that first, stool samples are preserved (e.g., in formalin) and can therefore be analyzed in the laboratory several days or weeks after stool collection, and second, this method allows diagnosis of both helminths and intestinal protozoa²⁴.

It is important to note, however, that the aforementioned techniques have shortcomings, particularly in low-infection intensity settings^{7,11}. For example, the McMaster technique—of which there are at least three variants (for details see ref. 18)—has an analytic sensitivity of 50 EPG for the 'modified McMaster method' and the 'modified and further improved McMaster method' or 10 EPG in the case of the 'special modification of the McMaster method.' Clearly, even the highest analytic sensitivity here is inadequate for

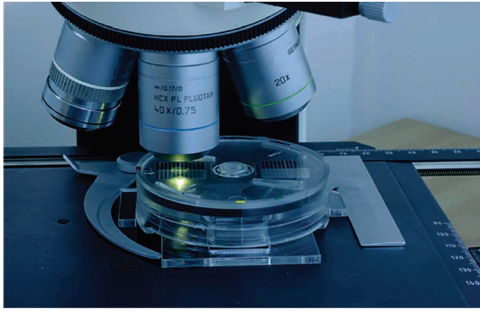

Figure 1 | The FLOTAC apparatus.

rigorous parasitological diagnosis¹¹. Similarly, the small amount of feces examined using the Kato-Katz technique (usually 41.7 mg) underlies its low analytic sensitivity of 24 EPG. The sensitivity of the Kato-Katz method is further compromised by day-to-day and intraspecimen variation of helminth egg output^{25–33}, problems related to time delays from fresh fecal sample production, collection in the field and processing in the laboratories, and rapid overclearing of hookworm eggs^{34,35}.

With regard to the Wisconsin technique, when the number of eggs is high, inefficiencies may arise due to the lack of precision in the egg counting procedures²² owing to the absence of a grid on the coverslip. Shortcomings of the ether-based concentration method include fire and explosion hazard, some PEs might be broken or altered, and hence underdiagnosed, and the method is qualitative rather than quantitative²³.

Hence, it is necessary to develop and validate new diagnostic tools for human and veterinary public health applications. Mes *et al.*¹¹ have recently developed a method based on salt–sugar flotation that can be used to obtain clear preparations of nematode eggs from ruminant feces. However, the salt–sugar flotation technique has thus far only been used for detection of eggs of gastrointestinal nematodes in livestock.

Another important, yet often neglected, issue is that infection by multiple species of parasite is the norm rather than the exception, both in the veterinary and in human fields, particularly in developing world settings^{36–41}. The paucity of diagnostic tools that are able to detect multiple-species parasitic infection with a high level of accuracy is an important underlying reason why so little is known about multiparasitism. For example, in human studies⁴², repeated sampling of fecal material and the concurrent use of different diagnostic tools are recommended for research purposes. Examinations of stool samples using both the Kato-Katz and the ether-based concentration methods enhance the sensitivity for diagnosing *Schistosoma mansoni* and common soil-transmitted helminth (*Ascaris lumbricoides*, hookworm and *Trichuris trichiura*) infections. Diagnosis of concurrent *Strongyloides stercoralis* infections requires the use of additional methods, such as Koga agar plate⁴³ and Baermann⁴⁴. Hence, a combination of methods, ideally used on consecutive stool samples, is necessary to assess the true extent of polyparasitism.

FLOTAC techniques

In this study, we present protocols for the FLOTAC techniques⁴⁵, which are a series of recently developed multivalent, copromicroscopic techniques based on the same principle but with a host of different potential applications. These techniques use the FLOTAC

apparatus (Fig. 1) and are based on the centrifugal flotation of a fecal sample suspension and subsequent translation of the apical portion of the floating suspension. The initial development of the FLOTAC was inspired from other flotation-based techniques, particularly the McMaster and Wisconsin methods. However, a central feature of the FLOTAC techniques is that they provide counts of PEs in large fecal aliquots (up to 1 g or even higher amounts of fecal material). The FLOTAC techniques were initially developed for veterinary parasitology^{45–53}, but have more recently been extended to human parasitology and broad-scale validation is underway for diagnosis of major nematodes and trematodes parasitizing humans^{33,54,55}, including *S. mansoni* (D. Glinz and colleagues, unpublished data), and intestinal protozoa.

Advantages and disadvantages of the FLOTAC techniques have been summarized recently³³. One shortcoming is that a certain level of laboratory infrastructure (e.g., large volume centrifuge or benchtop centrifuge with rotor for microtiter plates) is required for the FLOTAC techniques, which is often not available in resource-constrained settings. Moreover, as for other FEC techniques based on flotation, the choice of FS and preservation medium might influence the performance of the FLOTAC techniques and care is indicated with some materials because of environmental and human toxicity. Finally, it should be noted that—at present—the FLOTAC apparatus (components, accessories and manuals for human, dog and herbivores) is not commercially available. However, should the broad-scale validation of the FLOTAC techniques be successfully completed, we intend to provide these resources free of charge to WHO, research institutions and other public institutions interested in copromicroscopic diagnosis of parasites.

Basic principles. The FLOTAC apparatus is a cylindrical-shaped device made of polycarbonate amorphous thermoplastic. This material has been chosen because of excellent light transmission, high heat resistance, robustness (can be washed and re-used many times) and high-dimensional stability. The FLOTAC apparatus

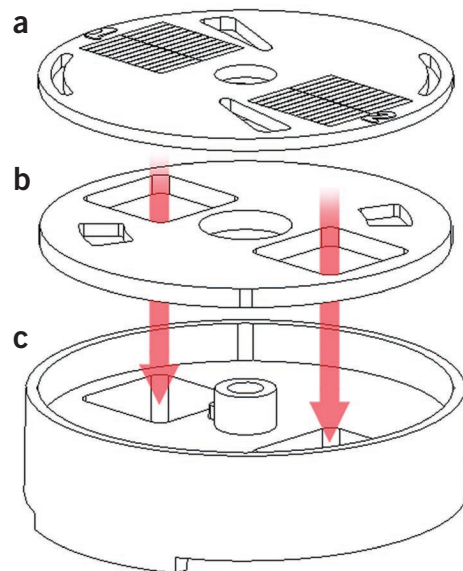

Figure 2 | Physical components of the FLOTAC apparatus. The core device is composed of reading disk (a), translation disc (b) and base (c). Arrows indicate flotation chambers (modified from Cringoli (2006) and reprinted with permission from *Parassitologia*).

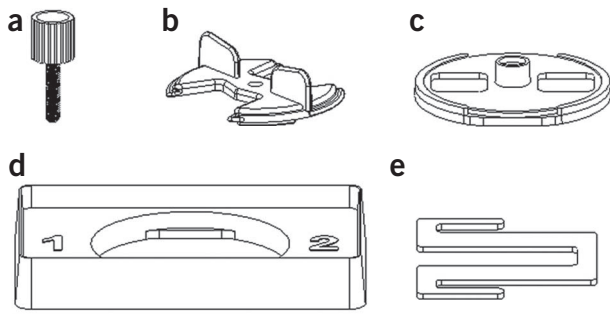

Figure 3 | Accessories of the FLOTAC apparatus. These include screw (a), key (b), bottom (c), centrifuge adapter (d) and microscope adapter (e) (originally published in reference 45, reprinted with permission from *Parassitologia*).

comprises three physical components, namely the base (Fig. 2a), the translation disc (Fig. 2b) and the reading disc (Fig. 2c). There are two 5-ml flotation chambers, which are designed for optimal examination of large fecal sample suspensions in each flotation chamber (total volume = 10 ml).

There are five accessories, namely the screw (Fig. 3a), the key (Fig. 3b), the bottom (Fig. 3c), the centrifuge adapter (Fig. 3d) and the microscope adapter (Fig. 3e). These accessories are mandatory for proper functioning of the FLOTAC apparatus during centrifugation and subsequent examination under a microscope. The full FLOTAC assembly process is shown in Figure 4, whereas the execution of the post-centrifugation translation step is depicted in Figure 5.

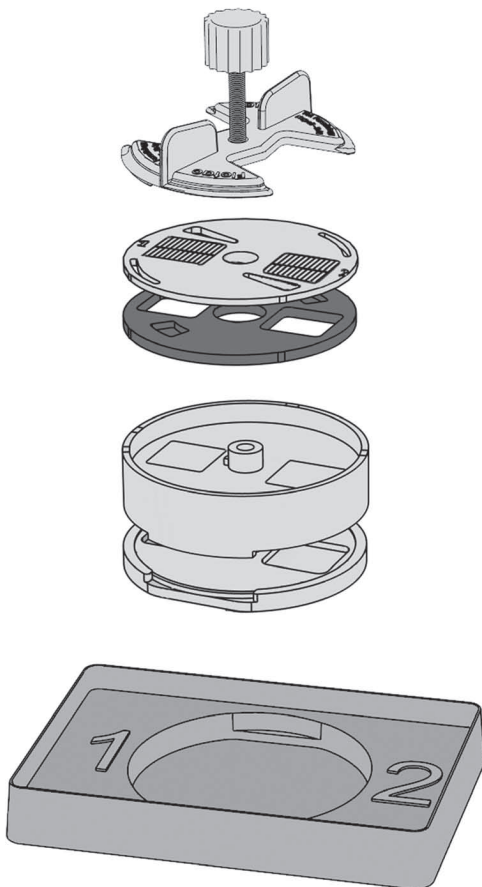

Figure 4 | Full FLOTAC assembly process showing core elements and accessories.

There are two versions of the FLOTAC apparatus: FLOTAC-100, which permits a maximum magnification of $\times 100$ (Fig. 6a), and FLOTAC-400, which permits a maximum magnification of $\times 400$ (Fig. 6b). FLOTAC-400 is a further development and improvement over FLOTAC-100, as it allows microscopic diagnosis at a four fold higher magnification compared with FLOTAC-100, which is necessary for detection of intestinal protozoa. FLOTAC-100, however, is still suggested for the diagnosis of helminth eggs and larvae, and for teaching purposes, because the reading disc is considerably thicker and hence more robust than the one used in FLOTAC-400, and because the flotation chambers can be filled more easily.

Experimental design. The accuracy of any copromicroscopic technique, in terms of how well the observed values (e.g., number of PEs per gram of stool) agree with the ‘true’ values, greatly depends on the modes of fecal sampling. In this regard, it is useful to consider a fecal sample as a part of the whole intestinal material (WIM) present in the gastrointestinal tract of the host in which the PEs are distributed. For bovines and other large animals, it is advisable to collect fecal samples directly from the rectum. For other animals and humans, it might be useful to collect fecal material over a complete defecation (total fecal material, TFM). The larger the fecal sample, the more representative it is for the WIM. As ‘gold’ standard fecal sampling, one could consider excretion of the WIM within 24 h, which corresponds to 1 TFM. As PEs are not evenly distributed in the feces, thorough homogenization of the TFM is important before the sampling procedure. The fecal sample should weigh at least 10 times the fecal aliquot to be examined. Larger fecal aliquots will result in more accurate FECs. It is common that for small animals and humans the fecal aliquot corresponds to the fecal sample.

All three FLOTAC techniques (basic, dual and double) can be performed on fresh fecal material, feces stored at 4 °C for 1–3 d and preserved fecal samples stored in 5 or 10% formalin or sodium acetate-acetic acid-formalin (SAF) for several weeks or months.

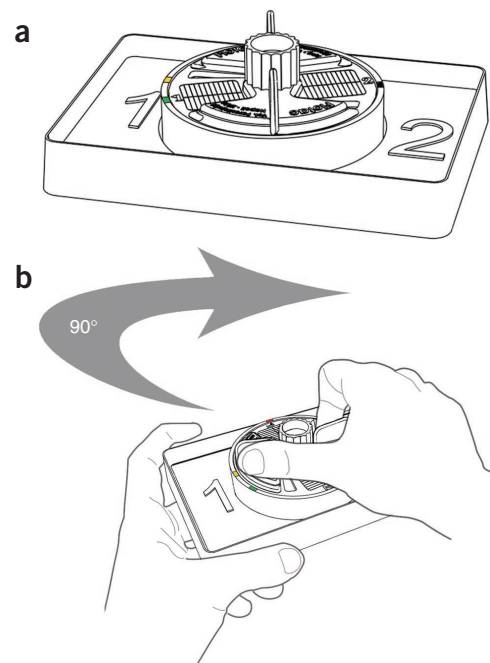

Figure 5 | Some details of the FLOTAC assembly and operating steps. The FLOTAC apparatus completely assembled (a) and execution of the post-centrifugation translation step (b).

PROTOCOL

Fecal samples should be preserved at a ratio of 1:4, as follows: one part of feces plus three parts of fixative (5 or 10% formalin or SAF). Efforts should be made to thoroughly homogenize feces and the fixative (e.g., manual stirring of feces with a wooden or plastic spatula) as soon as they are put into a container. This container should be hermetically closed and labeled with a unique identifier, including the date of stool collection.

Experiences obtained thus far suggest that the use of fresh feces produce the most accurate results. Formalin 5% produced more accurate results than other fecal preservatives. It is advisable not to freeze fecal samples. For human and dog fecal samples, disposable sampling kits, which are part of the FLOTAC family of materials, are now available. They consist of a collector (Fig. 7a) and a filter (Fig. 7b). These kits facilitate the performance of the first five consecutive steps of the FLOTAC techniques: (i) collection (including weighing), (ii) transfer into fixative, (iii) homogenization, (iv) filtration and (v) transfer into tubes.

Operating steps. Either FLOTAC-100 or FLOTAC-400 can be used for performing the three FLOTAC techniques (basic, dual and double), which are variants of a single technique but have different applications. The 11 operating steps of the three FLOTAC techniques are summarized in Figure 8. The fundamentals of these variants are as follows (Fig. 9):

- The FLOTAC basic technique (Fig. 9a) uses a single FS. This technique is recommended for the study and/or diagnosis of



Figure 7 | The disposable FLOTAC fecal sampling kit. This consists of a collector (a) and a filter (b).

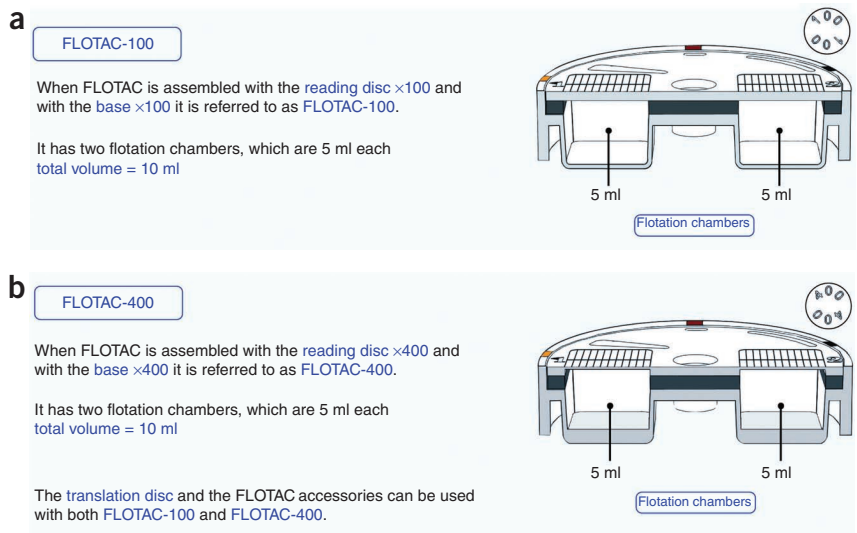

Figure 6 | The two versions of the FLOTAC apparatus. (a) The FLOTAC-100, suitable primarily for diagnosis of helminth eggs and larvae, and (b) the FLOTAC-400, which can also be used for diagnosis of intestinal protozoa.

fecal samples containing a low or very low number of PEs from a single parasite species (natural or experimental mono-infection), or from fecal samples containing a low or very low number of various types of PEs, which all have the same behavior with respect to the FS used. With the FLOTAC basic technique, the reference units are the two flotation chambers (total volume 10 ml, corresponding to 1 g of feces). The analytic sensitivity of the FLOTAC basic technique is 1 EPG, 1 LPG, 1 OPG or 1 CPG.

- The FLOTAC dual technique (Fig. 9b) is based on the use of two different FS that have complementary specific gravities (s.g.) and are used in parallel on the same fecal sample. This technique is suggested for epidemiological surveys and routine diagnosis in order to perform a wide-ranged parasitological screening of PEs with different characteristics concerning the use of FS. With the FLOTAC dual technique, the reference unit is the single flotation chamber (volume 5 ml; corresponding to 0.5 g of feces). The analytic sensitivity of the FLOTAC dual technique is 2 EPG, 2 LPG, 2 OPG or 2 CPG.
- The FLOTAC double technique (Fig. 9c) is based on the simultaneous examination of two different fecal samples from two different hosts using a single FLOTAC apparatus (Steps 1–8 are performed on two different fecal samples). With this technique, the two fecal samples are each assigned to its own single flotation chamber, using the same FS. With the FLOTAC double technique, the reference unit is the single flotation chamber (volume 5 ml). The analytic sensitivity of the FLOTAC double technique is 2 EPG, 2 LPG, 2 OPG or 2 CPG.

FS has a fundamental role in determining the analytic sensitivity (i.e., the smallest amount of PEs in a sample that can be assessed accurately), the precision (i.e., how well repeated observations agree with one another) and the accuracy (i.e., how well the observed values agrees with the 'true' values) of any analytical method (qualitative and/or quantitative) based on flotation. It should be noted that not all the FS available in specialized parasitology laboratories can be used with the FLOTAC techniques, and that some of the FS contain ingredients that are harmful for humans and the environment (e.g., mercury II iodide). This protocol includes a list

of nine different FS (chosen among those commonly described in the literature), with details given for their chemical composition and s.g., that have been recommended for the optimal recovery of PEs through FLOTAC techniques. Until new data have become available, it is advised not to use any FS other than those listed here.

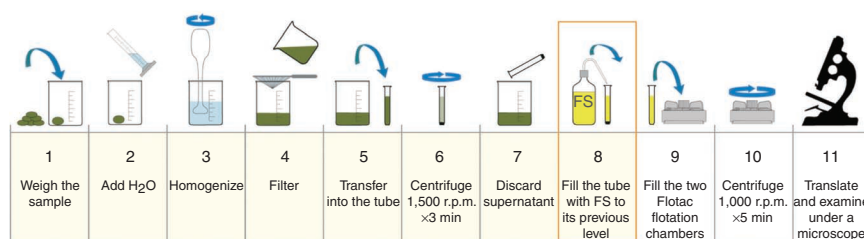

Figure 8 | The 11 operating steps of the FLOTAC techniques.

MATERIALS

REAGENTS

For FSs

- Sodium chloride (NaCl) (FS2) (AppliChem, cat. no. A1149)
- Sucrose (C₁₂H₂₂O₁₁) (FS1 and FS5) (AppliChem, cat. no. A3935)
- Formaldehyde (CH₂O), solution 40% (FS1) (LAB-SCAN, cat. no. A3548M) **! CAUTION** It is toxic to humans and dangerous for the environment.
- Zinc sulfate heptahydrate (ZnSO₄·7H₂O) (FS3, FS7 and FS9) (AppliChem, cat. no. A1000)
- Sodium nitrate (NaNO₃) (FS4) (AppliChem, cat. no. A3911)
- Mercury II iodide (HgI₂) (FS5, FS8 and FS9) (CARLO ERBA Reagents, cat. no. 461105) **! CAUTION** It is toxic to humans and dangerous for the environment.
- Potassium iodide (KI) (FS5, FS8 and FS9) (CARLO ERBA Reagents, cat. no. 472737)
- Magnesium sulfate (MgSO₄) (FS6) (AppliChem, cat. no. A1811)

For fixatives

- Formaldehyde (CH₂O), solution 40% (for formalin 5 and 10%, and SAF) (LAB-SCAN, cat. no. A3548M) **! CAUTION** It is toxic to humans and dangerous for the environment.
- Sodium acetate trihydrate (CH₃COONa·3H₂O) (for SAF) (AppliChem, cat. no. A1045)

- Acetic acid glacial (CH₃COOH) (for SAF) (CARLO ERBA Reagents, cat. no. 401422) **! CAUTION** It is corrosive and flammable.

For fat remover

- Ether (C₂H₅(2O)) (LAB-SCAN, cat. no. P09A11X) **! CAUTION** It is toxic to humans and dangerous for the environment.
- Ethyl acetate (CH₃COOCH₂CH₃) (Diagnostic International Distribution, cat. no. 1473) **! CAUTION** It is irritant to humans and flammable.
- Physiological saline (Sigma-Aldrich, cat. no. 07982100TAB-F)

EQUIPMENT

- Weighing scale **▲ CRITICAL** The weighing scale should have an accuracy of at least 0.1 g.
- Plastic containers
- Cylinders
- Hand-held blender
- Wooden or plastic spatula
- Wire mesh (i.e., metal sieve having an aperture of 250 μm)
- 15-ml plastic centrifuge tubes
- Pasteur pipettes
- FLOTAC-100 and/or FLOTAC-400
- Centrifuge: large volume centrifuge (with buckets of at least 75 mm diameter) or benchtop centrifuge with rotor for microtiter plates **▲ CRITICAL** In case no suitable electric centrifuge is in place, the centrifugation can also be performed using a hand centrifuge with special holding adapters for the FLOTAC apparatus, which are not commercially available but can be obtained from the first author.
- Microscope: conventional optical microscope **▲ CRITICAL** The microscope needs a travel range of at least 25 mm because the FLOTAC apparatus is 19-mm high.
- Hydrometer
- Magnetic stirrer
- Chemical safety cabinet

REAGENT SETUP

All FS and fixatives listed below can be stored at room temperature (20–25 °C) for at least 1 month.

FS1: Sheather's sugar solution (s.g., 1.20) Add 454 g of sucrose to 355 ml of tap water (corn syrup and dextrose are not suitable substitutes). Dissolve sugar in water by stirring on a magnetic stirrer over low or indirect heat (e.g., the top half of a double boiler). Once sugar is dissolved and the solution has cooled down to room temperature, add 6 ml of formaldehyde (40%) USP to prevent microbial growth. Check the s.g. with a hydrometer. **! CAUTION** Formaldehyde is toxic to humans and dangerous for the environment.

▲ CRITICAL If the container is placed on a direct heat source that is too hot, the sugar may caramelize instead of dissolving in water.

FS2: Saturated sodium chloride (NaCl) (s.g., 1.20) Add NaCl to 1 liter of warm water (40–50 °C) until no more salt goes into solution (~500 g) and the excess settles on the bottom of the container. Dissolve by stirring on a magnetic stirrer. To ensure that the solution is fully saturated, it should be allowed to stand overnight at room temperature. Check the s.g. with a hydrometer, recognizing that the s.g. of the saturated solution will vary slightly depending on ambient temperature. **▲ CRITICAL** If initially precipitated salt crystals dissolve overnight, more salt can be added to ensure that the solution is saturated.

FS3: Zinc sulfate (ZnSO₄·7H₂O) (s.g., 1.20) Add 330 g of zinc sulfate heptahydrate to 500 ml of tap water. Dissolve zinc sulfate in water with a magnetic stirrer. Add tap water to reach a final volume of 1 liter. Check the s.g. using a hydrometer.

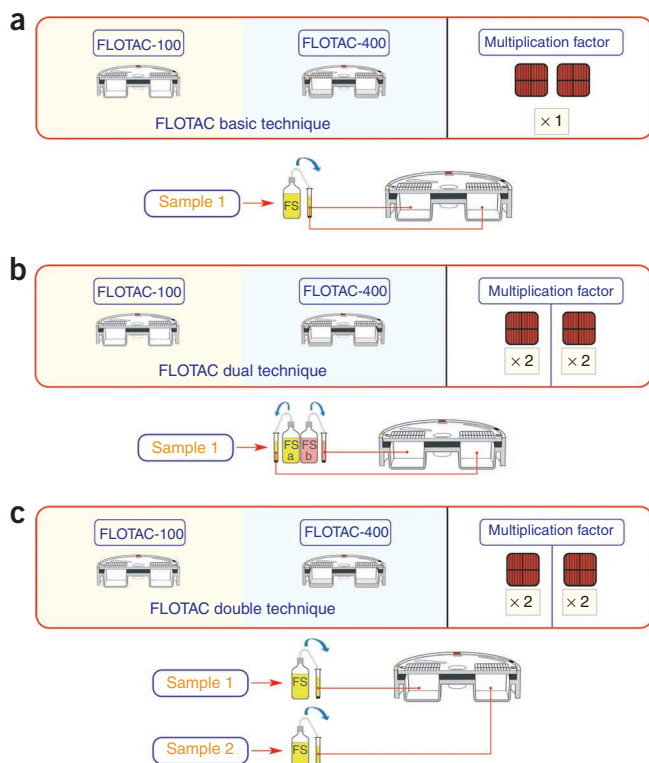

Figure 9 | Overview of the various FLOTAC methods. These schemes illustrate the differences between (a) FLOTAC basic technique, (b) FLOTAC dual technique and (c) FLOTAC double technique.

PROTOCOL

FS4: Sodium nitrate (NaNO_3) (s.g., 1.20) Add 315 g of sodium nitrate to 500 ml of tap water. Dissolve sodium nitrate in water with a magnetic stirrer. Add tap water to reach a final volume of 1 liter. Check the s.g. with a hydrometer.

FS5: Sucrose and potassium iodomercurate (Rinaldi's solution) (s.g., 1.25) Add 600 g of sucrose to 600 ml of tap water. Dissolve sugar in water with a magnetic stirrer over low or indirect heat (e.g., the top half of a double boiler). Once sugar has dissolved and the solution has cooled down to room temperature, add 20 ml of solution B (see below). Check the s.g. with a hydrometer. **▲ CRITICAL** If the container is placed on a direct heat source that is too hot, the sugar may caramelize instead of dissolving in water.

Solution B Add 100 g of mercury (II) iodide to 63 ml of tap water. Stir vigorously. Add 78 g of potassium iodide and stir again. **! CAUTION** Mercury (II) iodide is toxic to humans and harmful to the environment. Working under a chemical safety cabinet is advised when mercury (II) iodide is used.

FS6: Magnesium sulfate (MgSO_4) (s.g., 1.28) Add 350 g of magnesium sulfate to 500 ml of tap water. Dissolve magnesium sulfate in water with a magnetic stirrer. Add tap water to reach a final volume of 1 liter. Check the s.g. with a hydrometer.

FS7: Zinc sulfate ($\text{ZnSO}_4 \cdot 7\text{H}_2\text{O}$) (s.g., 1.35) Add 685 g of zinc sulfate heptahydrate to 685 ml of tap water. Dissolve zinc sulfate in water by stirring on a magnetic stirrer. Check the s.g. with a hydrometer.

FS8: Potassium iodomercurate (s.g., 1.44) Add 150 g of mercury (II) iodide to 399 ml of tap water. Stir vigorously. Add 111 g of potassium iodide and stir again. Check the s.g. with a hydrometer. **! CAUTION** It is toxic to humans and harmful to the environment. Working under a chemical safety cabinet is advised when mercury (II) iodide is used.

FS9: Zinc sulfate and potassium iodomercurate (s.g., 1.45) Add 600 g of zinc sulfate heptahydrate ($\text{ZnSO}_4 \cdot 7\text{H}_2\text{O}$) to 600 ml of tap water. Dissolve zinc sulfate in water by stirring on a magnetic stirrer. Once zinc sulfate has been dissolved, add solution B (see below). Check the s.g. with a hydrometer.

Solution B Add 100 g of mercury (II) iodide to 63 ml of tap water. Stir vigorously. Add 78 g of potassium iodide and stir again. **! CAUTION** It is toxic to humans and harmful to the environment. Working under a chemical safety cabinet is advised when mercury (II) iodide is used.

Formalin 5% Add 5 ml of formaldehyde (40%) USP to 95 ml of deionized water. Stir vigorously and transfer into a suitable container.

Formalin 10% Add 10 ml of formaldehyde (40%) USP to 90 ml of deionized water. Stir vigorously and transfer into a suitable container.

SAF Add 1.5 g of sodium acetate hydrate to 92.5 ml of deionized water. Add 2 ml of acetic acid glacial. Add 4 ml of formaldehyde (40%) USP (Note that SAF fixative is also commercially available.) Stir vigorously and transfer into a suitable container. **! CAUTION** Formaldehyde is toxic to humans and harmful to the environment. Working under a chemical safety cabinet is advised when formaldehyde is used.

PROCEDURE

Sample collection

1| Fecal sample collection varies according to the sample being analyzed. Follow the steps in option A for samples from herbivores, option B for samples from omnivores and carnivores, and option C for samples from humans. Suggestions regarding preservation and fixation are discussed in the Experimental design section.

(A) Collection of fecal samples from herbivores (cattle, buffaloes, horses, sheep and goats) ● TIMING 1–2 min

- (i) Procure disposable gloves and collect a fecal sample (as much as possible) directly from the rectum. Alternatively (applies mainly for young animals), collect the fecal sample (as much as possible) from different parts of the TFM eliminated on a dry, clean floor using gloves or plastic bags. Turn the gloves or plastic bags inside out, tie in a knot, label with unique identifier and date. For routine shipment to specialized reference laboratories, fecal samples can be cooled down to 4 °C and then packed with ice or another coolant for shipment through courier services.

▲ CRITICAL STEP Fecal samples must be delivered within 24–48 h. Vacuum packing permits storage for longer periods. Fresh fecal samples must be handled with care because of the potential health hazards (e.g., use disposable gloves and regularly wash hands with soap).

- (ii) In the laboratory, thoroughly homogenize the fecal sample (using a spatula) and subject an aliquot of 5–10 g (depending on the species and size) to the respective FLOTAC technique.

(B) Collection of fecal samples from dogs (or other carnivores/omnivores) ● TIMING 1–2 min

- (i) Collect TFM on a dry, clean surface (e.g., plastic sheet or cardboard sheet). The TFM from which fecal samples are taken should, if possible, be the total amount of feces eliminated within a 24-h period.
- (ii) Thoroughly homogenize (using a spatula) the TFM and transfer 1–5 g of feces (depending on the size) into a clean container.
- (iii) In the laboratory, thoroughly homogenize the fecal sample (using a spatula) and subject to the respective FLOTAC technique.

! CAUTION Fecal samples must be delivered within 24–48 h. Vacuum packing permits storage for longer periods. Fresh fecal samples must be handled with care because of the potential health hazards (e.g., use disposable gloves and regularly wash hands with soap).

▲ CRITICAL STEP The type of diet (which can produce undesirable residues and fats in the feces) may influence the clarity of reading due to the flotation of small and/or large debris.

? TROUBLESHOOTING

(C) Collection of fecal samples from humans ● TIMING 1–2 min

- (i) Collect TFM on a dry, clean surface (e.g., plastic sheet or cardboard sheet). The TFM from which fecal samples are taken should, if possible, be the total amount of feces excreted within a 24-h period.
- (ii) Thoroughly homogenize (using a spatula) the TFM and transfer 1–5 g of feces (depending on the size) into a clean container.
- (iii) In the laboratory, thoroughly homogenize the fecal sample (using a spatula) and subject to the respective FLOTAC technique.

▲ **CRITICAL STEP** Fresh fecal samples must be delivered within 24–48 h. Vacuum packing permits storage for longer periods.

▲ **CRITICAL STEP** The type of diet (which can produce undesirable residues and fats in the feces) may influence the clarity of reading due to the flotation of small and/or large debris. Whenever and wherever feasible (e.g., asymptomatic patients from developed countries), special diet might be suggested during the days preceding the fecal sampling (e.g., avoid consumption of dry green legumes, fruits, pears, strawberries, figs and carrots and fruits with a thick skin such as peaches, apricots and tomatoes).

! **CAUTION** Fresh fecal samples must be handled with care because of the potential health hazards (e.g., use disposable gloves and regularly wash hands with soap).

? **TROUBLESHOOTING**

Sample preparation for FLOTAC

- 2| Dilute each collected fecal sample in tap water (dilution ratio 1:10).
- 3| Homogenize the sample thoroughly (the use of a hand blender is suggested).
- 4| Filter suspension through a wire mesh (aperture of 250 µm).
- 5| The following steps describe the various FLOTAC protocols that may now be performed. Perform the steps in option A for the FLOTAC basic technique, option B for the FLOTAC dual technique or option C for the FLOTAC double technique.
 - (A) **FLOTAC basic technique (one sample, one FS) ● TIMING 9–10 min**
 - (i) Place 11 ml of filtered suspension into a conic tube. The two flotation chambers of the FLOTAC apparatus require 5 ml each (total volume of 10 ml); an additional 1 ml is necessary in order to easily fill the two flotation chambers.
 - (ii) Centrifuge the tube for 3 min at 170g at room temperature.
 - (iii) After centrifugation, discard the supernatant, leaving only the sediment (pellet) in the tube.

? **TROUBLESHOOTING**
 - (iv) Fill the tube with the chosen FS to the previous 11 ml level.
 - (v) Thoroughly homogenize the suspension (before and between the fillings) and fill the two flotation chambers of the FLOTAC apparatus.

? **TROUBLESHOOTING**
 - (vi) Close the FLOTAC apparatus and centrifuge for 5 min at 120g at room temperature.
 - (vii) After centrifugation, translate the top parts of the flotation chambers and examine under a microscope.
 - (B) **FLOTAC dual technique (one sample, two different FS) ● TIMING 9–10 min**
 - (i) Transfer two 6 ml aliquots of the filtered suspension into two conic tubes. The two flotation chambers of the FLOTAC apparatus require 5 ml each; an additional 1 ml is necessary in order to easily fill each flotation chamber.
 - (ii) Centrifuge the two tubes for 3 min at 170g at room temperature.
 - (iii) After centrifugation, discard the supernatant, leaving only the sediments (pellets) in the tubes.

? **TROUBLESHOOTING**
 - (iv) Fill the two tubes with two different FS, denoted as FSa and FSb, up to the previous 6 ml level.
 - (v) Thoroughly homogenize the suspensions (before and between the fillings) and fill the two flotation chambers of the FLOTAC apparatus with the two fecal suspensions: chamber 1 with suspension in FSa and chamber 2 with suspension in FSb.

? **TROUBLESHOOTING**
 - (vi) Close the FLOTAC apparatus and centrifuge for 5 min at 120g at room temperature.
 - (vii) After centrifugation, translate the top parts of the flotation chambers and examine under a microscope.
 - (C) **FLOTAC double technique (two different samples, one FS) ● TIMING 9–10 min**
 - (i) Place 6 ml of each filtered suspension of each sample into a conic tube. The two flotation chambers of the FLOTAC apparatus require 5 ml each; an additional 1 ml is necessary in order to easily fill each flotation chamber.
 - (ii) Centrifuge tubes for 3 min at 170g at room temperature.
 - (iii) After centrifugation, discard the supernatant, leaving only the sediment (pellet) in each tube.

? **TROUBLESHOOTING**
 - (iv) Fill each tube with the chosen FS to the previous 6 ml level.
 - (v) Thoroughly homogenize suspensions (before and between the fillings) and fill each of the two flotation chambers of the FLOTAC apparatus: the first flotation chamber with sample 1 and the second flotation chamber with sample 2.

? **TROUBLESHOOTING**
 - (vi) Close the FLOTAC apparatus and centrifuge for 5 min at 120g at room temperature.
 - (vii) After centrifugation, translate the top parts of the flotation chambers and examine under a microscope.

PROTOCOL

● TIMING

Step 1, to setup the equipment, FS and fixative: approximately 3–4 h

Steps 2–4, FLOTAC method: approximately 12–15 min

Step 5, to examine the FLOTAC apparatus under a microscope: between 30 s and 5 min depending on diversity and quantities of PEs.

As they are multivalent, the FLOTAC techniques are flexible in timing regarding the number of parasitological diagnoses that can be completed. For example, 20–25 FLOTAC examinations can be performed by one person during a single day. Considering that up to 15 different parasites may be detected in a sheep stool sample by the FLOTAC dual technique, more than 100 parasitological diagnoses—perhaps even 200 diagnoses—can be performed daily.

With regard to all the FLOTAC techniques, the density of PEs and the presence of undesirable residues in the feces (small or large debris) can affect the timing and the accuracy of the reading. When the PEs per gram (PEG) are greater than 500, it is advisable to either: dilute the sample suspensions or choose smaller reading areas for counting. When there are undesirable residues in the feces (small or large debris), it is advisable to dilute the sample suspensions. Our experience thus far in routine diagnosis is that dilution greater than 1:10 are suggested for humans (1:25) and for sheep and goats (from 1:30 to 1:50). **Figure 10** shows fecal dilutions and FLOTAC reading areas suggested for different ranges of FECs.

? TROUBLESHOOTING

Troubleshooting advice can be found in **Table 1**.

TABLE 1 | Troubleshooting guides for the FLOTAC techniques.

Step	Problem	Possible reason	Solution
Step 1 (B–C) iii and Step 5(A–C) iii for all FLOTAC techniques (basic, dual and double)	Reading difficulty	Fecal samples rich in fats	<p>After Step 5(A–C) iii of all FLOTAC techniques, use ether (E) or ethyl acetate (EA) as a lipid removing agent, as follows:</p> <ol style="list-style-type: none">1. Add 10 ml of physiological saline (SAL) and 2 ml of E (C₂H₅(20)) or EA, or alternatively, 7 ml of SAL + 3 ml of E/EA, to the pellet; stir vigorously for 30–60 s by hand, or at least 15 s on a vortex2. Centrifuge for 3 min at 120g. Three layers should result: the sediment layer containing the PE, a layer of fats in the middle and a layer of E/EA at the top3. Discard the supernatant leaving only the pellet in the tube and clean the edges of the tube using cotton to remove the fat residues <p>Continue from Step iv of the chosen FLOTAC technique. If it is necessary to first remove the E/EA residue from the pellet, wash it with water or SAL as follows:</p> <ol style="list-style-type: none">4. Add tap water or SAL to reach a final volume of 15 ml5. Homogenize the suspension thoroughly6. Centrifuge for 3 min at 120g7. Discard the supernatant <p>▲ CRITICAL STEP The use of E, and even more so of EA, may damage some types of PEs (e.g., eggs of hookworm, <i>Ascaris</i> spp. and larvae of <i>Strongyloides</i> spp.)</p>
Step 5(A–C) v for all FLOTAC techniques (basic, dual and double)	Formation of air bubbles, especially when using FLOTAC-400	Too vigorous homogenization of fecal suspension in tubes; improper filling of chambers (especially for FLOTAC-400)	<p>Homogenize the suspension gently</p> <p>Fill chamber 1 with the FLOTAC apparatus on the centrifuge adapter inclined toward the technician and chamber 2 on the centrifuge adapter inclined away from the technician</p> <p>When using FLOTAC-400, greater inclinations are required</p>

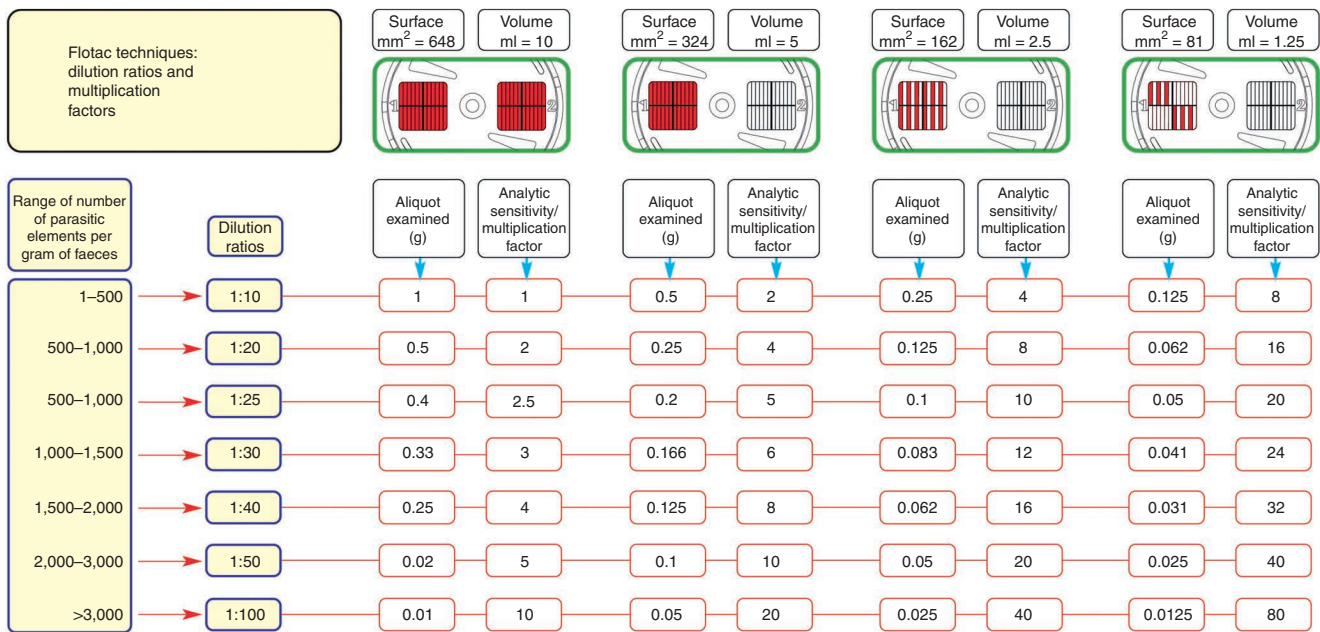

Figure 10 | Fecal dilutions and FLOTAC reading areas suggested for different ranges of FECs.

ANTICIPATED RESULTS

Effective applications of FLOTAC

Figure 11 shows the FLOTAC apparatus containing the prepared fecal sample and the reading grid under a microscope, ready for examination, i.e., quantification of PEs. Studies carried out thus far showed that the FLOTAC techniques are accurate and have a high sensitivity for detecting helminth eggs and larvae in animal and human feces. For example, in dogs, FLOTAC techniques have been successfully used for the diagnosis of *Crenosoma vulpis*⁴⁶ and *Spirocerca lupi*⁵². In cat feces, accurate detection of *Aelurostrongylus abstrusus* larvae has been reported⁴⁹. FLOTAC produced promising results for *Passalurus ambiguus* diagnosis in rabbits⁴⁷ and *Trichuris* spp. in simians⁵³.

With regard to humans, the FLOTAC techniques have been used for diagnosis of the three common soil-transmitted helminths, namely the hookworms (*Ancylostoma duodenale* and *Necator americanus*), roundworm (*A. lumbricoides*) and whipworm (*T. trichiura*). A single FLOTAC examination has shown higher sensitivity than multiple Kato-Katz thick smears, with particularly promising results obtained in the settings characterized by low helminth infection intensities^{33,54,55}. In addition, in a recent study carried out in Côte d'Ivoire, the FLOTAC techniques were successfully employed for the diagnosis of *S. mansoni* and results were compared with the Kato-Katz and the ether-based concentration methods (D. Glinz and colleagues, unpublished data). Finally, a series of explorative studies are under way for diagnosis of intestinal protozoa in animals and humans.

Results from both published^{46,47,56} and unpublished studies that compared FLOTAC with other FEC techniques showed the following strengths and limitations:

- The number of false negatives using FLOTAC was markedly lower than those observed by other techniques, demonstrating the high diagnostic sensitivity of the FLOTAC techniques.
- In animal studies, the mean EPGs of helminths when using FLOTAC were either equal to or greater than those obtained with other techniques.
- In human studies, the mean EPGs of helminths when using FLOTAC sometimes were lower compared with other techniques, an issue that warrants further investigation to determine the root causes of these discrepancies.
- Considerably lower variations in EPGs have been obtained by FLOTAC compared with other methods, indicating high precision and accuracy of FLOTAC.

The FLOTAC techniques have been designed for use by researchers and for specialized laboratories where there is a need for highly accurate and precise results (e.g., national reference laboratories for copromicroscopic diagnosis

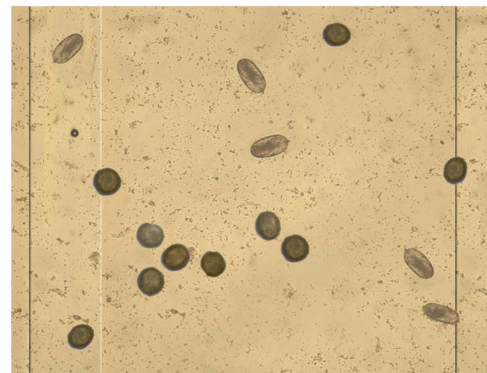

Figure 11 | Microscope image of the FLOTAC apparatus with sample within grid ready for quantitative egg count examination.

PROTOCOL

of parasites). In such specialized laboratories, precise results are often more important than the simplicity of the technique or the cost of the technique chosen. Should the ongoing validation of the FLOTAC techniques reveal that this approach is indeed more sensitive than other, currently more widely used techniques, further efforts will be made to enhance simplicity and cost-effectiveness.

Considerations in sample preparation

Numerous different factors may influence the performance of the FLOTAC techniques, as with any copromicroscopic technique based on flotation (e.g., simple flotation, McMaster and Wisconsin) and sedimentation. These can include the choice of fixative used for fecal preservation (e.g., formalin 5 or 10%, or SAF), the duration of fecal preservation before FLOTAC analyses, and the selection of the FS and the concurrent use of ether.

For techniques based on flotation, the choice of FS is important but, in our view, does not receive sufficient consideration by the scientific community, despite the substantial effect that the FS can have on the diagnostic performance of any flotation technique⁵⁷. Usually, in the manuals of diagnostic parasitology or in the peer-reviewed literature, only the s.g. or density is reported for FS. It is commonly believed that the efficiency of a FS in terms of the capacity to bring PEs to float increases as the s.g. of the FS increases. However, PEs should not be considered 'inert elements'⁵⁷. Instead, interactions between the elements within a floating fecal suspension (e.g., FS components, PE, fixative, ether and residues of the host alimentations) might be complex and new research is needed to elucidate potential interactions between these elements. As a rule of thumb, it is noteworthy that:

- Different FS with the same s.g. do not produce the same results with respect to the same PE, even when the same technique is used.
- A given FS, which might be highly efficient with respect to a given PE, using a given technique, does not produce the same results if the technique is changed.
- A given FS, which is efficient with respect to a given PE, using a given technique on a fresh fecal sample, does not produce the same results if the method of fecal preservation changes (e.g., frozen, preserved in formalin or SAF, or in other fixatives).
- It may happen that a given FS, which is efficient with respect to a given PE, using a given technique, does not produce the same results if the diet of the host changes.

It follows that when a copromicroscopic technique based on flotation is employed, each PE must be considered independently with respect to the FS, the technique and the method of fecal preservation used. What is known for a given PE cannot be readily translated to a 'similar' PE, or to the same PE when the technique or the fecal preservation method changes.

TABLE 2 | Experiences obtained thus far using FLOTAC techniques for diagnosis of parasites harbored in different animal host species (cattle, buffalo, sheep, goat, cat, dog, and horse) and humans, depending on the fecal preservation, parasitic elements and flotation solution.

Host	Fecal preservation	Parasite	Parasitic element (PE)	Flotation solution (FS) and specific gravity (s.g.)								
				FS1 1.20	FS2 1.20	FS3 1.20	FS4 1.20	FS5 1.25	FS6 1.28	FS7 1.35	FS8 1.44	FS9 1.45
Cattle, buffalo, sheep and goat	Fresh	<i>Eimeria</i> spp.	Oocysts	+	++	+	+	+++	++	+	+	#
Cattle, buffalo, sheep and goat	Fresh	Gastrointestinal strongyles	Eggs	+++	+++	++	++	+++	++	++	+	+
Cattle, buffalo, sheep and goat	Fresh	<i>Moniezia</i> spp.	Eggs	++	++	+++	++	++	+++	++	+	++
Cattle, buffalo, sheep and goat	Fresh	<i>Fasciola hepatica</i>	Eggs (shells)	#	#	#	#	#	#	+++	+	+++
Cattle, buffalo, sheep and goat	Fresh	<i>Calicophoron daubneyi</i>	Eggs (shells)	#	#	#	#	#	#	+++	+	+++
Cattle, buffalo, sheep and goat	Fresh	<i>Dicrocoelium dendriticum</i>	Eggs	#	#	#	#	#	#	++	+++	++

(continued)

TABLE 2 | Continued.

Host	Fecal preservation	Parasite	Parasitic element (PE)	Flotation solution (FS) and specific gravity (s.g.)								
				FS1 1.20	FS2 1.20	FS3 1.20	FS4 1.20	FS5 1.25	FS6 1.28	FS7 1.35	FS8 1.44	FS9 1.45
Cattle, buffalo, sheep and goat	Fresh	Lungworm	Larvae (L ₁)	#	#	++	#	#	+	++	+	+++
Horse	Fresh	<i>Parascaris equorum</i>	Eggs	+	++	+	+++	+++	+	+	+	+
Horse	Fresh	<i>Anoplocephala</i> spp.	Eggs	+++	+	+	+	+	+	+	#	+
Horse	Fresh	Strongyles	Eggs	+	+++	+	+	+++	+	+	+	+
Cat and dog	Fresh	<i>Toxocara</i> spp.	Eggs	+++	+	++	++	+	+++	+++	+	++
Cat and dog	Fresh	<i>Toxascaris leonina</i>	Eggs	++	++	++	++	++	+++	+	+	+
Cat and dog	Fresh	<i>Trichuris</i> spp.	Eggs	+++	++	++	+++	++	++	++	++	+
Cat and dog	Fresh	Hookworm	Eggs	++	+++	++	++	++	++	+	+	+
Dog	Fresh	<i>Angyostrongylus</i> spp.	Larvae (L ₁)	+	#	+++	+	+	++	++	+	+++
Dog	Fresh	<i>Crenosoma</i> spp.	Larvae (L ₁)	++	#	+++	#	++	+	+	#	+
Human (*)	SAF-preserved	<i>Ascaris lumbricoides</i> (**)	Eggs	+++	+	+	++	+++	++	+	+	+
Human (*)	SAF-preserved	Hookworm (**)	Eggs	+	+++	+	+++	++	+	+	+	+
Human (*)	SAF-preserved	<i>Trichuris trichiura</i>	Eggs	+++	+	+	++	+++	+	+	+	+
Human (*)	SAF-preserved	<i>Schistosoma mansoni</i>	Eggs	#	#	#	#	#	#	+++	+	++

+++ most efficient; ++ efficient; + less efficient; # not suggested; (*) work in progress. (**) do not use ether.

Once the influence of FS and fecal preservation methods are duly taken into account, some of the advantages and multivalence of the FLOTAC techniques might become apparent. Using the appropriate FS and fixatives, the FLOTAC techniques can diagnose PEs from helminths (eggs or larvae of nematodes, cestodes and trematodes) and intestinal protozoa (cysts and oocysts). This is very important also from a practical point of view because, at present, there is no single method available to detect multiple helminths and intestinal protozoa with high sensitivity and accuracy in a single fecal sample, and yet multiple species parasitic infections in both animals and humans are the norm rather than the exception in many parts of the world.

Table 2 summarizes experiences gained thus far with the FLOTAC techniques for diagnosis of parasites in different hosts. It should be noted that the nine FSs detailed in our protocols are those commonly described in the literature. Some of them are based on the use of mercury (II) iodide, which has been classified by the European Union as toxic and dangerous for the environment, and hence should be avoided if at all possible, especially in places with no or inappropriate waste control. In such cases, these can be replaced by other FSs.

An advantage of the FLOTAC techniques, besides robustness, is the opportunity to work with preserved fecal samples, enabling easy programming of daily laboratory activities and, more importantly, ensuring the safety of laboratory personnel who are presently exposed to health hazards as many of the recommended diagnostics are to be performed only on fresh stool samples.

In conclusion, results obtained thus far with FLOTAC show that these are promising techniques for precise and accurate detection and quantification of PEs in human and animal feces. At present, the FLOTAC techniques are particularly useful for specialized reference laboratories. It is conceivable that the FLOTAC techniques will have an important role for research and monitoring purposes (e.g., assessment of anthelmintic drug efficacy and monitoring of drug resistance). Further validations of the FLOTAC techniques for diagnosis of helminths and intestinal protozoa



parasitizing both animals and humans in different epidemiological settings are urgently needed and we invite those who are interested in using and further validating the FLOTAC techniques to get in touch with us. We hope that the use of the FLOTAC techniques will help the advancement and standardization of quality procedures for human and veterinary public health.

ACKNOWLEDGMENTS G.C. acknowledges Giuseppe and Massimo Federico for their technical expertise and their enthusiasm in participating in the development of the FLOTAC apparatus. G.C. also acknowledges Maria Elena Morgoglione, Sabrina Carbone, Mirella Santaniello, Saverio Pennacchio, Antonio Santaniello and Vincenzo Musella for their participation in the application and validation of the FLOTAC techniques. J.U. acknowledges financial support from the Swiss National Science Foundation (project no. PPOOB-102883; PPOOB-119129).

AUTHOR CONTRIBUTIONS G.C. invented the FLOTAC apparatus and the FLOTAC techniques; L.R., M.P.M. and J.U. participated in the application and validation of the techniques. All authors read, revised and approved the final submitted paper.

COMPETING INTERESTS STATEMENT The authors declare competing financial interests (see the HTML version of this article for details).

Published online at <http://www.natureprotocols.com/>.
Reprints and permissions information is available online at <http://npg.nature.com/reprintsandpermissions/>.

- Banoo, S. *et al.* (TDR Diagnostics Evaluation Expert Panel). Evaluation of diagnostic tests for infectious diseases: general principles. *Nat. Rev. Microbiol.* **4**, S17–S27 (2006).
- Kenyon, F. *et al.* The role of targeted selective treatments in the development of refugia-based approaches to the control of gastrointestinal nematodes of small ruminants. *Vet. Parasitol.* **164**, 3–11 (2009).
- Albonico, M., Engels, D. & Savioli, L. Monitoring drug efficacy and early detection of drug resistance in human soil-transmitted nematodes: a pressing public health agenda for helminth control. *Int. J. Parasitol.* **34**, 1205–1210 (2004).
- WHO. *Preventive Chemotherapy in Human Helminthiasis—Coordinated Use of Anthelmintic Drugs in Control Interventions: A Manual for Health Professionals and Programme Managers* 1–62 (World Health Organization, Geneva, Switzerland, 2006).
- Doenhoff, M.J., Cioli, D. & Utzinger, J. Praziquantel: mechanisms of action, resistance and new derivatives for schistosomiasis. *Curr. Opin. Infect. Dis.* **21**, 659–667 (2008).
- Ridley, R.G. Diagnostics take centre stage. *Nat. Rev. Microbiol.* **4**, S1 (2006).
- Bergquist, R., Johansen, M.V. & Utzinger, J. Diagnostic dilemmas in helminthology: what tools to use and when? *Trends Parasitol.* **25**, 151–156 (2009).
- Gordon, H.M. & Whitlock, H.V. A new technique for counting nematode eggs in sheep faeces. *J. Counc. Sci. Ind. Res.* **12**, 50–52 (1939).
- Whitlock, H.V. Some modifications of the McMaster helminth egg-counting technique and apparatus. *J. Counc. Sci. Ind. Res.* **21**, 177–180 (1948).
- Cox, D.D. & Todd, A.C. Survey of gastrointestinal parasitism in Wisconsin dairy cattle. *J. Am. Vet. Med. Assoc.* **141**, 706–709 (1962).
- Mes, T.H., Eysker, M. & Ploeger, H.W. A simple, robust and semi-automated parasite egg isolation protocol. *Nat. Protoc.* **2**, 486–489 (2007).
- Kato, T. & Miura, M. On the comparison of some stool examination methods. *Jpn. J. Parasitol.* **3**, 35 (1954).
- Katz, N., Chaves, A. & Pellegrino, J. A simple device for quantitative stool thick-smear technique in *Schistosomiasis mansoni*. *Rev. Inst. Med. Trop. São Paulo* **14**, 397–400 (1972).
- Ritchie, L.S., Pan, C. & Hunter, G.W. A comparison of the zinc sulphate and the MGL (formalin-ether) technics. *J. Parasitol.* **38**, 16 (1952).
- Allen, A.V.H. & Ridley, D.S. Further observations on the formalin-ether concentration technique for faecal parasites. *J. Clin. Pathol.* **23**, 545–546 (1970).
- Wood, I.B. *et al.* World Association for the Advancement of Veterinary Parasitology (W.A.A.V.P.) second edition of guidelines for evaluating the efficacy of anthelmintics in ruminants (bovine, ovine, caprine). *Vet. Parasitol.* **58**, 181–213 (1995).
- Coles, G.C. *et al.* The detection of anthelmintic resistance in nematodes of veterinary importance. *Vet. Parasitol.* **136**, 167–185 (2006).
- UK Ministry of Agriculture, Fisheries and Food. *Manual of Veterinary Parasitological Laboratory Techniques* (Freeman and Company, New York, 1986).
- Roepstorff, A. & Nansen, P. *FAO Animal Health Manual*, vol. 3. (United Nations Food and Agriculture Organization, Rome, Italy, 1998).
- Pereckienė, A. *et al.* A comparison of modification of the McMaster method for the enumeration of *Ascaris suum* eggs in pig faecal samples. *Vet. Parasitol.* **149**, 111–116 (2007).
- Karamon, J., Ziomko, I., Cencek, T. & Sroka, J. Modified flotation method with the use of Percoll for the detection of *Isospora suis* oocysts in suckling piglet faeces. *Vet. Parasitol.* **156**, 324–328 (2008).
- Egwand, T.G. & Slocombe, J.O. Evaluation of the Cornell-Wisconsin centrifugal flotation technique for recovering trichostrongylid eggs from bovine feces. *Can. J. Comp. Med.* **46**, 133–137 (1982).
- Utzinger, J. *et al.* Microscopic diagnosis of sodium acetate-acetic acid-formalin-fixed stool samples for helminths and intestinal protozoa: a comparison among European reference laboratories. *Clin. Microbiol. Infect.* **16**, 267–273 (2010).
- Cheesbrough, M. Parasitological tests. In *District Laboratory Practice in Tropical Countries. Tropical Health Technologies*. 178–306 (Cambridge University Press, Cambridge, UK, 2005).
- de Vlas, S.J. & Gryseels, B. Underestimation of *Schistosoma mansoni* prevalences. *Parasitol. Today* **8**, 274–277 (1992).
- Engels, D., Sinzinkayo, E. & Gryseels, B. Day-to-day egg count fluctuation in *Schistosoma mansoni* infection and its operational implications. *Am. J. Trop. Med. Hyg.* **54**, 319–324 (1996).
- Engels, D., Sinzinkayo, E., de Vlas, S.J. & Gryseels, B. Intraspecimen fecal egg count variation in *Schistosoma mansoni* infection. *Am. J. Trop. Med. Hyg.* **57**, 571–577 (1997).
- Ye, X.P., Donnelly, C.A., Fu, Y.L. & Wu, Z.X. The non-randomness of the distribution of *Trichuris trichiura* and *Ascaris lumbricoides* eggs in faeces and the effect of stirring faecal specimens. *Trop. Med. Int. Health* **2**, 261–264 (1997).
- Utzinger, J. *et al.* Relative contribution of day-to-day and intra-specimen variation in faecal egg counts of *Schistosoma mansoni* before and after treatment with praziquantel. *Parasitology* **122**, 537–544 (2001).
- Booth, M., Vounatsou, P., N’Goran, E.K., Tanner, M. & Utzinger, J. The influence of sampling effort and the performance of the Kato-Katz technique in diagnosing *Schistosoma mansoni* and hookworm co-infections in rural Côte d’Ivoire. *Parasitology* **127**, 525–531 (2003).
- Enk, M.J., Lima, A.C., Drummond, S.C., Schall, V.T. & Coelho, P.M. The effect of the number of stool samples on the observed prevalence and the infection intensity with *Schistosoma mansoni* among a population in an area of low transmission. *Acta Trop.* **108**, 222–228 (2008).
- Knopp, S. *et al.* Diagnosis of soil-transmitted helminths in the era of preventive chemotherapy: effect of multiple stool sampling and use of different diagnostic techniques. *PLoS Negl. Trop. Dis.* **2**, e331 (2008).
- Knopp, S. *et al.* FLOTAC: a promising technique for detecting helminth eggs in human faeces. *Trans. R. Soc. Trop. Med. Hyg.* **103**, 1190–1194 (2009).
- Martin, L.K. & Beaver, P.C. Evaluation of Kato thick-smear technique for quantitative diagnosis of helminth infections. *Am. J. Trop. Med. Hyg.* **17**, 382–391 (1968).
- Dacombe, R.J. *et al.* Time delays between patient and laboratory selectively affect accuracy of helminth diagnosis. *Trans. R. Soc. Trop. Med. Hyg.* **101**, 140–145 (2007).
- Zinsstag, J., Ankers, P., Ndao, M., Bonfoh, B. & Pfister, K. Multiparasitism, production and economics in domestic animals in sub-Saharan West Africa. *Parasitol. Today* **14**, 46–49 (1998).
- Raso, G. *et al.* Multiple parasite infections and their relationship to self-reported morbidity in a community of rural Côte d’Ivoire. *Int. J. Epidemiol.* **33**, 1092–1102 (2004).
- Brooker, S. & Utzinger, J. Integrated disease mapping in a polyparasitic world. *Geospat. Health* **1**, 141–146 (2007).
- Pullan, R. & Brooker, S. The health impact of polyparasitism in humans: are we under-estimating the burden of parasitic diseases? *Parasitology* **135**, 783–794 (2008).
- Steinmann, P. *et al.* Extensive multiparasitism in a village of Yunnan province, People’s Republic of China, revealed by a suite of diagnostic methods. *Am. J. Trop. Med. Hyg.* **78**, 760–769 (2008).



41. Ellis, M.K. & McManus, D.P. Familial aggregation of human helminth infection in the Poyang lake area of China with a focus on genetic susceptibility to schistosomiasis japonica and associated markers of disease. *Parasitology* **136**, 699–712 (2009).
42. Knopp, S. *et al.* Spatial distribution of soil-transmitted helminths, including *Strongyloides stercoralis*, among children in Zanzibar. *Geospat. Health* **3**, 47–56 (2008).
43. Koga, K. *et al.* An evaluation of the agar plate method for the detection of *Strongyloides stercoralis* in northern Thailand. *J. Trop. Med. Hyg.* **93**, 183–188 (1990).
44. García, L.S. & Bruckner, D.A. *Diagnostic Medical Parasitology*, 1–791 (American Society for Microbiology, Washington, District of Columbia, 2001).
45. Cringoli, G. FLOTAC, a novel apparatus for a multivalent faecal egg count technique. *Parassitologia* **48**, 381–384 (2006).
46. Rinaldi, L. *et al.* *Crenosoma vulpis* in dog: first case report in Italy and use of the FLOTAC technique for copromicroscopic diagnosis. *Parasitol. Res.* **101**, 1681–1684 (2007).
47. Rinaldi, L., Russo, T., Schioppi, M., Pennacchio, S. & Cringoli, G. *Passalurus ambiguus*: new insights into copromicroscopic diagnosis and circadian rhythm of egg excretion. *Parasitol. Res.* **101**, 557–561 (2007).
48. Rinaldi, L. *et al.* Is gastrointestinal strongyle faecal egg count influenced by hour of sample collection and worm burden in goats? *Vet. Parasitol.* **163**, 81–86 (2009).
49. Gaglio, G., Cringoli, G., Rinaldi, L., Brianti, E. & Giannetto, S. Use of the FLOTAC technique for the diagnosis of *Aelurostrongylus abstrusus* in the cat. *Parasitol. Res.* **103**, 1055–1057 (2008).
50. Keiser, J. *et al.* Efficacy and safety of artemether against a natural *Fasciola hepatica* infection in sheep. *Parasitol. Res.* **103**, 517–522 (2008).
51. Keiser, J. *et al.* Anthelmintic activity of artesunate against *Fasciola hepatica* in naturally infected sheep. *Res. Vet. Sci.* **88**, 107–110 (2010).
52. Traversa, D. *et al.* Copromicroscopic and molecular assays for the detection of cancer-causing parasitic nematode *Spirocerca lupi*. *Vet. Parasitol.* **157**, 108–116 (2008).
53. Levecke, B., De Wilde, N., Vandenhoute, E. & Vercruyssen, J. Field validity and feasibility of four techniques for the detection of *Trichuris* in simians: a model for monitoring drug efficacy in public health? *PLoS Negl. Trop. Dis.* **3**, e366 (2009).
54. Utzinger, J. *et al.* FLOTAC: a new sensitive technique for the diagnosis of hookworm infections in humans. *Trans. R. Soc. Trop. Med. Hyg.* **102**, 84–90 (2008).
55. Knopp, S. *et al.* A single FLOTAC is more sensitive than triplicate Kato-Katz for the diagnosis of low-intensity soil-transmitted helminth infections. *Trans. R. Soc. Trop. Med. Hyg.* **103**, 347–354 (2009).
56. Cringoli, G. *et al.* Egg count calibration of the FLOTAC, McMaster and tube flotation techniques on *Ancylostoma caninum* eggs in dog faeces. *Proceedings of the LXIII Congress of the Italian Society of Veterinary Sciences*, Udine, Italy, 16–18 September 2009.
57. Cringoli, G., Rinaldi, L., Veneziano, V., Capelli, G. & Scala, A. The influence of flotation solution, sample dilution and choice of McMaster technique in estimating the faecal egg counts of gastrointestinal strongyles and *Dicrocoelium dendriticum* in sheep. *Vet. Parasitol.* **123**, 121–131 (2004).